

# Mercedes-Benz Vito Compact Van EU5

## Vehicle Dimensions (mm)

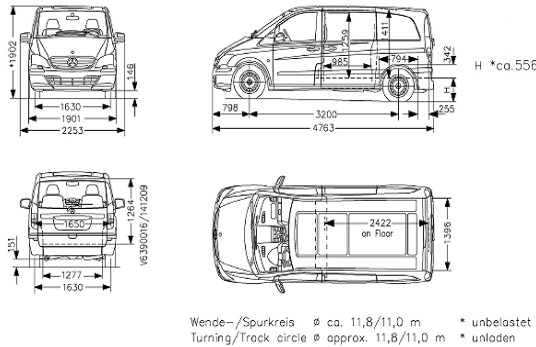

## Technical Data

Model	Mercedes Vito 110CDI Compact Van	Mercedes Vito 113CDI Compact Van	Mercedes Vito 116CDI Compact Van	
<b>Engine</b>				
Emission Compliance	EU5			
No. of cylinders	4			
Bore/Stroke/Capacity	88 mm/88.3 mm/2143 cc			
Rated output	70 kW(95 hp) @ 3800rpm	100 kW(136 hp) @ 3800rpm	120 kW(163 hp) @ 3800rpm	
Rated torque	250 Nm @ 14-2400 rpm	310 Nm @ 14-2600 rpm	360 Nm @ 16-2400 rpm	
Fuel System	Electronically controlled diesel direct injection with common rail, turbocharger and intercooler			
<b>Tank/electrics</b>				
Tank capacity, fuel type	Approx. 75l, Diesel			
Battery	12V/74 Ah			
Alternator	120A			
<b>Performance data</b>				
Top speed (calculated)	98mph/157km/h	98mph/157km/h	98mph/157km/h	
<b>Powertrain</b>				
Drive	Rear-wheel drive			
Clutch type/diameter	SDP / 228			
Transmission	Manual 6-speed			
Gear ratios Top/first	0.67/5.07			
Standard axle ratio	3.73	3.46	3.46	
<b>Chassis</b>				
Front Axle	Independent suspension; McPherson suspension with anti-roll bar, coil springs and shock absorbers			
Rear Axle	Independent suspension; semi-trailing arm suspension, coil springs and shock absorbers			
Anti roll bar Front/Rear	Standard/N/A			
Wheels	Steel wheels, 6J x 16 : Tyres 195/65R16			
Steering	Rack & Pinion			
Brakes	Hydraulic dual-circuit brake with vacuum booster; disc brakes all round, internally ventilated at front; ADAPTIVE ESP (Electr. Stability Programme) dynamic handling control system with ABS (anti-lock braking system), ASR (acceleration skid control). BAS (hydr. Brake Assist), EBD (electr. brake force distribution). ADAPTIVE ESP is additionally able to adapt its interventions to the Vito's current load.			
Power Assisted Steering	Standard			
<b>Weight rating kg</b>				
Kerb Weight* (FA/RA/total)	1120 / 750 / 1870			
Payload	930			
Permissible Axle Loads (FA/RA)	1470 / 1470			
Gross vehicle weight/gross combination weight	2800 / 4800			
GTW braked/unbraked	4800 / 3550			

## CAB

<b>Access to cab:</b>	Wide opening driver and passenger doors. Plastic coated entry steps.
<b>Security:</b>	Remote central locking; Thatcham Cat 2 engine immobiliser; Attack resistant steering lock; door locks and handles; interlocked radio CD.
<b>Airbags:</b>	Driver's airbag standard with belt tensioner and belt-force limiter. Front passenger airbag, thorax airbags and window bags can also be specified as options.
<b>Seating &amp; Trim</b>	3-way adjustable driver's seat with head restraint; dual passenger seat; three point inertia reel seat belts to all seats. Lima black seat material; door mounted arm rests; passenger grab handle; moulded ergonomic fascia; padded steering wheel with impact resistance centre; cab headlining.
<b>Refinements:</b>	Comprehensive insulation from road and engine noise; ashtray; cab interior lighting; cup holder; cigarette lighter; stereo radio/CD with integral Bluetooth mobile phone capability with two speakers.
<b>Controls:</b>	Dash mounted gear lever; multifunction steering wheel; speedtronic variable speed limiter; central locking switch in dashboard; hazard warning lights; headlamp levelling switch; headlamp rotary switch; heater and demister with multiple outlets; horn in centre of steering wheel; key start with steering lock and transponder engine immobiliser (FBS3); left hand stalk for indicators, wipers, main beam and headlamp flasher.
<b>Instruments:</b>	ASSYST - flexible servicing system; coolant temperature gauge; digital clock; digital odometer with trip computer; fuel level display; rev counter; speedometer.
<b>Warning Lights:</b>	ESP/ABS/ASR/EBD warning lights; brake pad wear; coolant temperature; engine pre-heater; lamp failure; low coolant level; low brake fluid; low engine oil; malfunction in the restraint system; open door; parking brake; rear fog lamp.
<b>Visibility:</b>	Electrically operated side windows and fixed quarterlights; laminated windscreen; two sunvisors, swivelling to the side, driver's side with map pocket. Reflector style headlamps with integral dim-dip daytime driving feature. Fog lights integral in front headlamp unit.

## CONSTRUCTION AND FINISH

<b>Storage:</b>	Illuminated glovebox; storage compartments in dashboard; storage within driver's and passenger doors; tool kit and storage area under driver's seat.
<b>Construction:</b>	All steel integral body/cab.
<b>Body protection:</b>	100% galvanised body; zinc phosphate treatment, KTL cathodic dip primer and gloss paint finish; underbody and wheel arches are undersealed with SSF chip resistant coating and rust inhibitor.
<b>Service Access:</b>	Internally released hinged bonnet for access to - air filter with condition indicator; clutch/brake fluid; engine coolant; engine oil dipstick/filler cap; power steering reservoir; windscreen washer reservoir.
<b>Bumpers:</b>	Moulded in damage-resistant, impact-absorbing plastic.
<b>Spare Wheel:</b>	Spare wheel mounted underneath rear of vehicle. Hydraulic jack and tools included. On Compact: Spare wheel mounted on inside of load area. Hydraulic jack and tools included.

---

## CARGO AREA

<b>Side Access:</b>	Twin sliding side load doors.
<b>Rear Access:</b>	Top hinged solid tailgate.
<b>Interior:</b>	Ceiling light in load compartment, with switch on dashboard; wooden floor with bonded resin non-slip finish; flat-topped wheel arches.
<b>Load Restraint:</b>	Load lashing rings recessed in floor.
<b>Warranty:</b>	3-year/Unlimited miles vehicle warranty* 12-year anti-perforation warranty* * Terms & Conditions apply

### Terms & Conditions

Please refer to the latest editions of the Mercedes-Benz Recommended List Price documents for availability and prices of models and optional equipment. The right is reserved to alter specification or equipment without notice. All specifications refer to vehicles sourced in the UK from Mercedes-Benz UK Ltd or their appointed Mercedes-Benz Retail Partners. All weights and dimensions quoted are approximate and subject to normal manufacturing tolerances of +/- 5%.